



MAX9583 Evaluation Kit

Evaluates: MAX9583

General Description

The MAX9583 evaluation kit (EV kit) is an assembled and tested PCB that demonstrates the MAX9583 dual-channel, standard-definition video filter amplifier with DC-coupled inputs. The EV kit operates from 2.7V to 3.6V with a fixed gain of 2V/V.

Component List

DESIGNATION	QTY	DESCRIPTION
C1	1	10 μ F \pm 20%, 6.3V X7R ceramic capacitor (0805) Murata GRM21BR70J106K
C2	1	0.1 μ F \pm 10%, 16V X7R ceramic capacitor (0603) Taiyo Yuden EMK107BJ104KA TDK C1608X7R1C104KT or equivalent
C3, C4	0	Not installed, aluminum electrolytic capacitors (6.3mm x 6.0mm)
IN_A, IN_B, OUT_A, OUT_B	4	75 Ω BNC PCB-mount jack connectors
R1–R4	4	75 Ω \pm 1% resistors (0603)
R5, R6	2	0 Ω \pm 5% resistors (0603)
U1	1	MAX9583AZT+T (6-pin Thin SOT23) Top Mark: AADJ
—	1	PCB: MAX9583 Evaluation Kit+

Component Suppliers

SUPPLIER	PHONE	WEBSITE
Murata Mfg. Co., Ltd.	770-436-1300	www.murata.com
Taiyo Yuden	800-348-2496	www.t-yuden.com
TDK Corp.	847-803-6100	www.component.tdk.com

Note: Indicate that you are using the MAX9583 when contacting these component suppliers.

Features

- ◆ 2.7V to 3.6V Single-Supply Operation
- ◆ 7MHz \pm 1dB Passband
- ◆ 62dB Attenuation at 27MHz
- ◆ Fully Assembled and Tested

Ordering Information

PART	TEMP RANGE	IC PACKAGE
MAX9583EVKIT+	0°C to +70°C*	6 Thin SOT23

+ Denotes a lead-free and RoHS-compliant EV kit.

* This limited temperature range applies to the EV kit PCB only. The MAX9583 IC temperature range is -40°C to +125°C.

Quick Start

Recommended Equipment

- A DC power supply capable of supplying a voltage between 2.7V to 3.6V at 500mA
- Video signal generator
- Video measurement equipment (e.g., Tektronix VM700T or equivalent)

Procedure

The MAX9583 EV kit is fully assembled and tested. Follow the steps below to verify board operation.

Caution: Do not turn on the power supply until all connections are completed.

- 1) Connect the power supply to the pads labeled VDD and GND on the MAX9583 EV kit.
- 2) Connect the desired test signals from the video signal generator to the IN_A and IN_B BNC connectors. The video signals at IN_A and IN_B must be between 0 and 1V, approximately.
- 3) Connect the output signals from the OUT_A and OUT_B BNC connectors to the inputs of the video measurement equipment.
- 4) Turn on the power supply and verify the output signals.

MAX9583 Evaluation Kit

Detailed Description

The MAX9583 EV kit demonstrates the MAX9583 low-power, dual-channel video filter amplifier with integrated reconstruction filters. The EV kit operates from 2.7V to 3.6V with a fixed gain of 2V/V.

The MAX9583 has $\pm 1\text{dB}$ (typ) passband flatness of 7MHz and 62dB attenuation at 27MHz and the outputs can be DC-coupled to a load of 75Ω , which is the equivalent of two video loads, or AC-coupled to a load of 150Ω .

AC-Coupling the Output

The outputs of the MAX9583 can be AC-coupled. To keep the highpass formed by the 150Ω equivalent resistance of the video transmission line to a corner frequency of 4.8Hz or lower, remove the 0Ω resistors on R5 and R6 and install $\geq 220\mu\text{F}$ coupling capacitors on C3 and C4 pads.

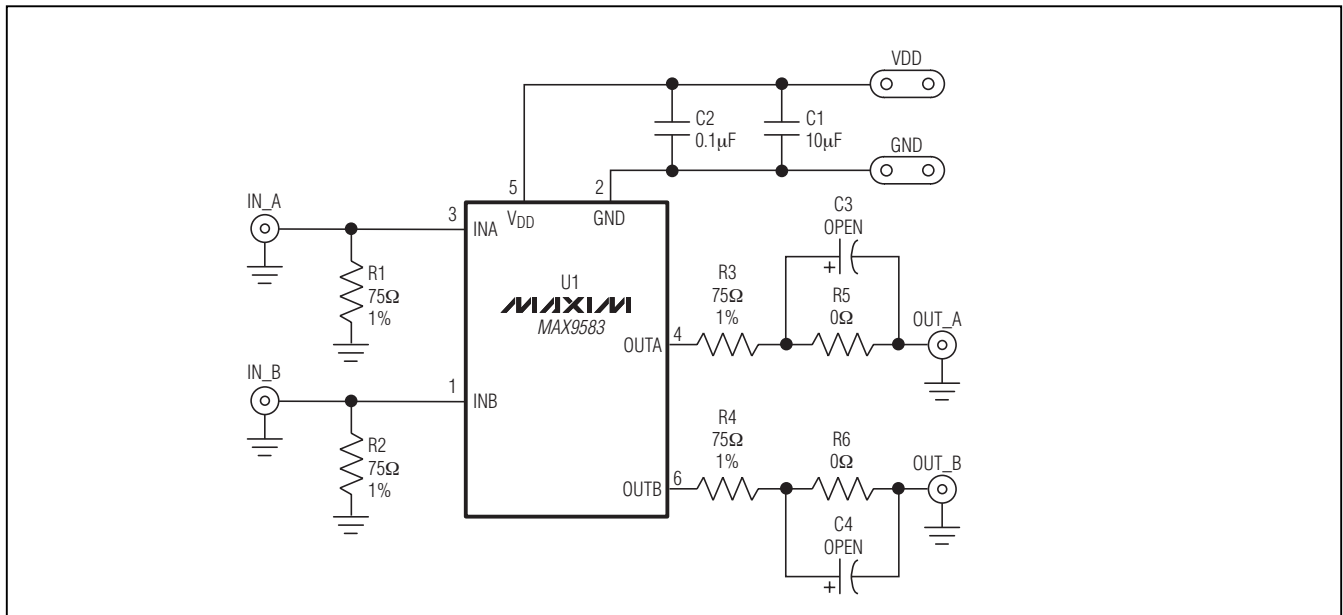

Figure 1. MAX9583 EV Kit Schematic

MAX9583 Evaluation Kit

Evaluates: MAX9583

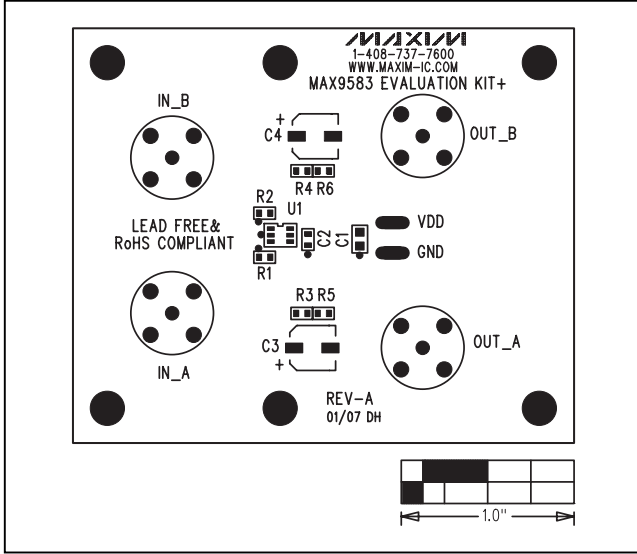

Figure 2. MAX9583 EV Kit Component Placement Guide—Component Side

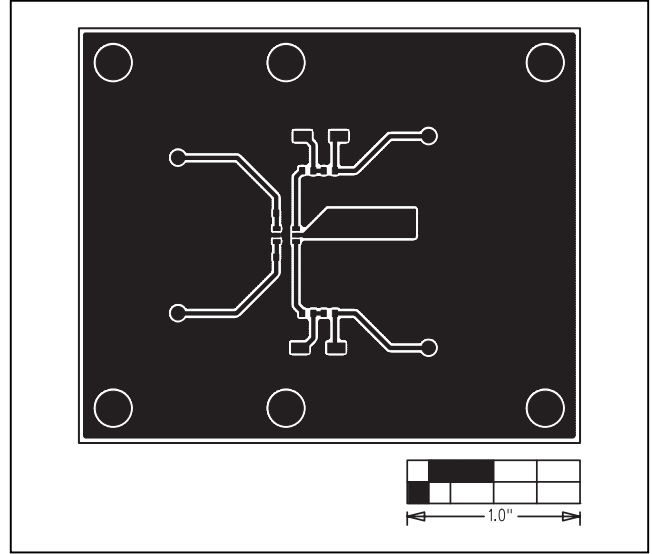

Figure 3. MAX9583 EV Kit PCB Layout—Component Side

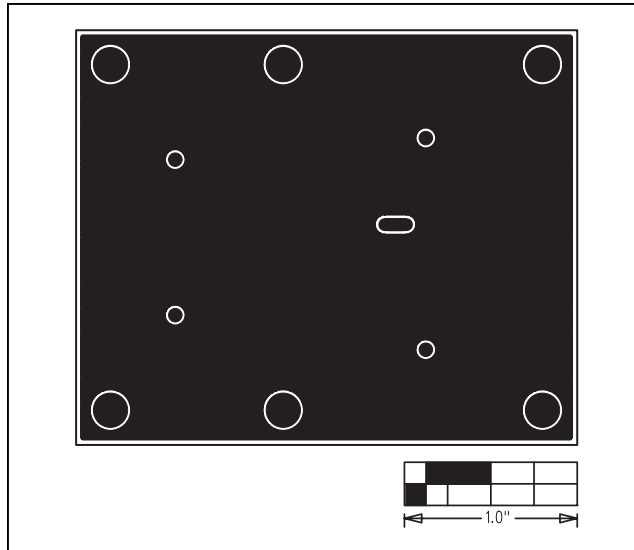

Figure 4. MAX9583 EV Kit PCB Layout—Solder Side

Maxim cannot assume responsibility for use of any circuitry other than circuitry entirely embodied in a Maxim product. No circuit patent licenses are implied. Maxim reserves the right to change the circuitry and specifications without notice at any time.

Maxim Integrated Products, 120 San Gabriel Drive, Sunnyvale, CA 94086 408-737-7600 _____ 3